

SCT2630A Evaluation Board User's Guide

FEATURES

- Wide Input Range: 4.5V-60V
- Up to 3A Continuous Output Current
- 0.8V \pm 1% Feedback Reference Voltage
- Integrated 80m Ω High-Side
- Ultra-Low Quiescent Current: 160uA
- Pulse Skipping Mode (PSM) in light load
- 130ns Minimum On-time
- 2ms Internal Soft-start Time
- Adjustable Frequency 100KHz to 2.5MHz
- External Clock Synchronization
- Precision Enable Threshold for Programmable Input Voltage Under-Voltage Lock Out Protection (UVLO) Threshold and Hysteresis
- Derivable Inverting Voltage Regulator
- Over-voltage and Over-Temperature Protection
- Available in an ESOP-8 Package

APPLICATIONS

- Industrial Distributed Power Supplies
- Battery Pack Powered System - Cordless Power Tools, Cordless Home Appliance, Drone etc.
- Cigarette Lighter Adapters, USB Chargers
- USB Type-C Power Delivery
- Optical Communication and Networking System

DESCRIPTION

The EV2630A-B-01A Evaluation Board is designed to demonstrate the capabilities of SCT2630A, high efficiency non-synchronous step-down DCDC converter supporting up to 3A continuous output current from an input source from 4.5V to 60V.

The SCT2630A features programmable switching frequency from 100 kHz to 2.5 MHz with an external resistor, which provides the flexibility to optimize either efficiency or external component size. The converter supports external clock synchronization with a frequency band from 100kHz to 2.5MHz. The device offers fixed 2ms soft start to prevent inrush current during the startup of output voltage ramping. The SCT2630A features external loop compensation to provide the flexibility to optimize either loop stability or loop response.

This user's guide describes the characteristics, operation and the use of the EV2630A-B-01A Evaluation Module including EVM specifications, recommended test setup, test result, schematic diagram, bill of materials, and the board layout.

Board Number	IC Number
EV2630A-B-01A	SCT2630A

PERFORMANCE SUMMARY

Parameter	Condition	Value
Input Voltage	DC up to 60V	4.5V-60V
Output Voltage	Iout=0A~3A	3.3V \pm 1%
Output Current	Continuous DC current	3A

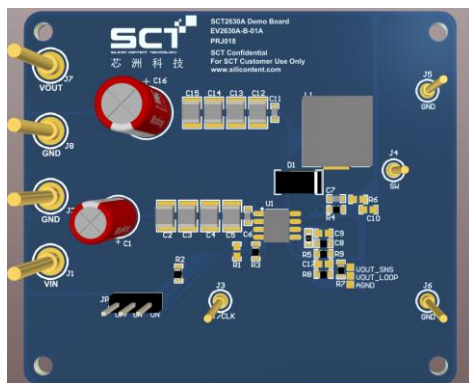

EV2630A-B-01A Evaluation Board Top View

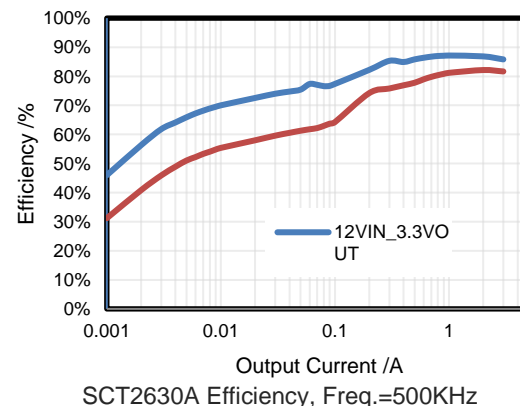

QUICK START PROCEDURE

Evaluation board EV2630A-B-01A is easy to set up to evaluate the performance of SCT2630A, synchronous step-down DCDC converter. Refer to Figure 1 for proper measurement equipment setup and follow the procedure below:

1. Place jumpers in the following positions:
 - J1, J2: Connect the power supply to the input of converter.
 - J7, J8: Connect the load to the output of converter.
 - JP1: Enable. Enable Jumper. Install ON shunt to connect EN pin to V_{in} through a 100K Ω resistor to enable IC. Install OFF shunt to disable IC.
2. With power off, connect the input power supply to J1 V_{in} connector and J2 GND connector. Make sure that the input voltage does not exceed 60V, and supports sufficient current limit. Turn on the power at the input.
3. Check the output voltage at J7 and J8. The output voltage should be 3.3V typical. Once the proper output voltage is established, adjust the load within the operating range and observe the output voltage regulation, output voltage ripple, efficiency and other parameters.
4. To use the enable function, apply a digital input to the EN pin of JP1.
5. Users can place C1 if input wire is long and C16 for better load transient performance.

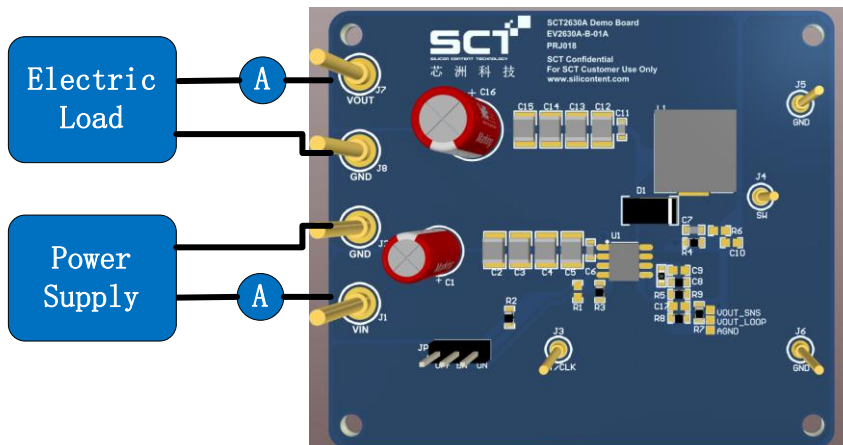

Figure 1. Power Supply, Load and Measurement Equipment Setup

NOTE: When measuring the voltage ripple, care must be taken to avoid a long ground lead on the oscilloscope probe. Measure the input or output voltage ripple by touching the probe tip directly across relevant capacitor of V_{in} or V_{out} . See Figure 2 for proper scope probe technique.



Figure 2. Measuring Voltage Ripple across Terminals or Directly Across Ceramic Capacitor

SCHEMATIC DIAGRAM

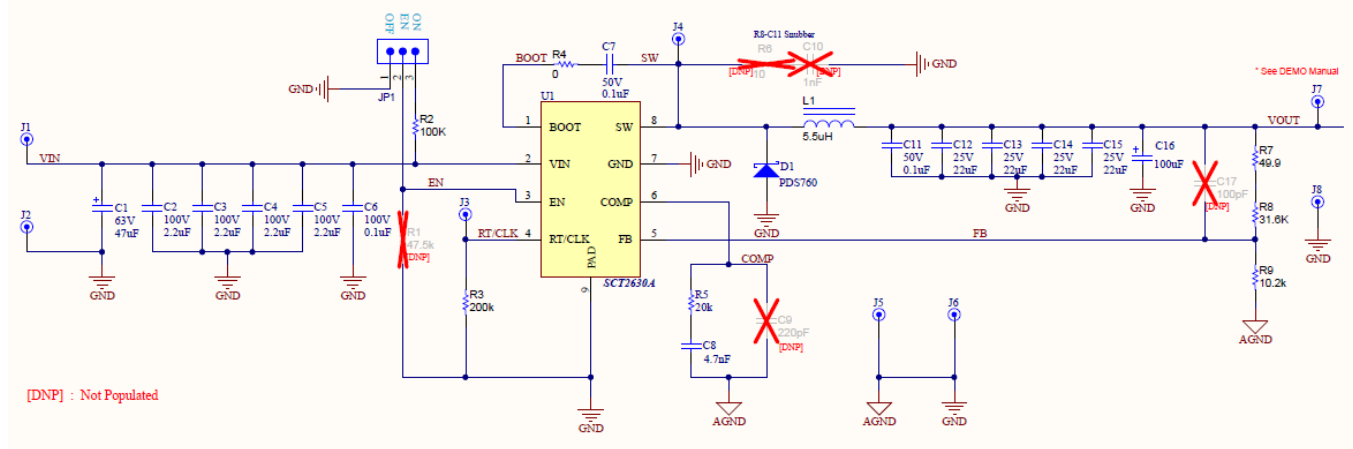

Figure 3. SCT2630A EVM Schematic

BILL OF MATERIALS

Table 1. SCT2630A EVM Bills of Materials

Footprint	PartNumber	Manufacture	Designator	Description	Quantity
'WCAP-ATG5	860020773013	Würth Electronix	C1	WCAP-ATG5 THT Aluminum Electrolytic Capacitors, 47uF, +/-20%, 63VDC	1
1210	885 382 209 002	Würth Electronix	C2, C3, C4, C5	CAP, CERM, 2.2u, 100 V, +/- 10%, X7R, 1210	4
1210	885 012 109 011	Würth Electronix	C12, C13, C14, C15	CAP, CERM, 47 uF, 16 V, +/- 10%, X5R, 1210	4
'WCAP-ATG5	860020674015	Würth Electronix	C16	WCAP-ATG5 THT Aluminum Electrolytic Capacitors, 100uF, +/-20%, 50VDC	1
0603	885 012 206 095	Würth Electronix	C11	CAP, CERM, 0.1 u, 50V, +/- 10%, X7R, 0603	1
0603	885 012 206 120	Würth Electronix	C6	CAP, CERM, 0.1 u, 100 V, +/- 10%, X7R, 0603	1
0603	885 012 206 095	Würth Electronix	C7	CAP, CERM, 0.1 u, 50 V, +/- 10%, X7R, 0603	1
0603	885 012 206 069	Würth Electronix	C8	CAP, CERM, 4.7nF, 25 V, +/- 10%, X7R, 0603	1
PDS760	PDS760	Diodes	D1	Schottky Diode,60V, 7A	1
Terminal_2.1	Terminal_2.1	Terminal	J1, J2, J7, J8	Power Terminal	4
Terminal_1.1	Terminal_1.1	Terminal	J3, J4, J5, J6	Test Point	4
CONN_PEC03SAA N	'613 003 111 21	Würth Electronix	JP1	Header, 100mil, 3x1, Tin plated, TH	1
WE-HCI_1050	744325650	Würth Electronix	L1	Inductor, Shielded Drum Core, , 5.5u, 8.4 A, 0.0125 ohm, SMD	1
0603	RC0603JR-07100KL	Vishay	R2	RES, 100 k, 1%, 0.1 W, 0603	1
0603	RC0603FR-07200KL	Vishay	R3	RES, 200k, 1%, 0.1 W, 0603	1
0603	CRCW06030000Z0EA	Vishay	R4	RES, 0, 5%, 0.1 W, 0603	1
R0603	RC0603FR-0720KL	Vishay	R5	RES, 20k, 1%, 0.1 W, 0603	1
0603	CRCW060349R9FKE A	Vishay	R7	RES, 49.9 1%, 0.1 W, 0603	1
0603	CR0603-FX-3162ELF	Vishay	R8	RES, 31.6K 1%, 0.1 W, 0603	1
0603	CRCW060310K2FKE A	Vishay	R9	RES, 10.2k, 1%, 0.1 W, 0603	1
SOP8	SCT2630A	SCT2630A	U1	4.5V-60V 输入, 3A, DCDC 转换器	1

PRINTED CIRCUIT BOARD LAYOUT

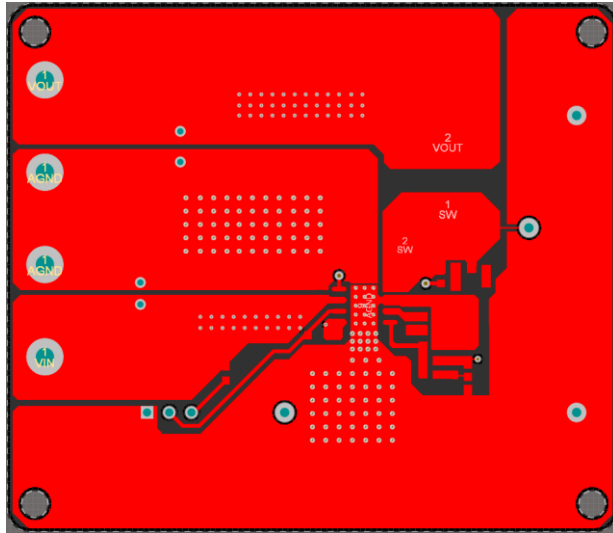

Figure 4. Top Layer

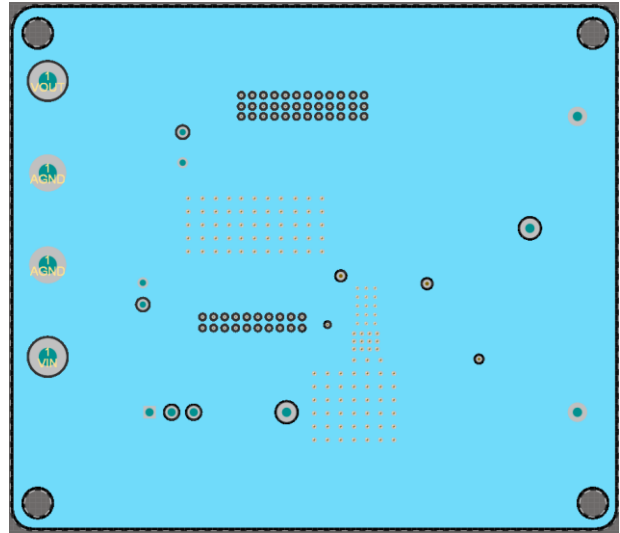

Figure 5. Internal 1 Layer

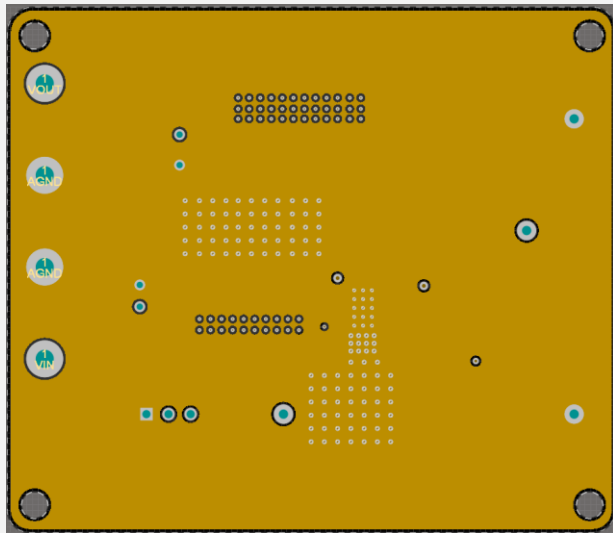

Figure 6. Internal 2 Layer

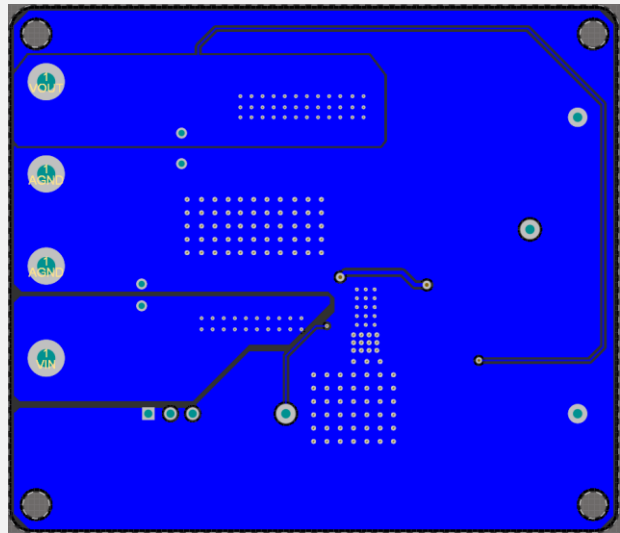

Figure 7. Bottom Layer

EVB TEST RESULTS

Unless otherwise noted, Vin=12V, Vout=3.3V, Load=3A

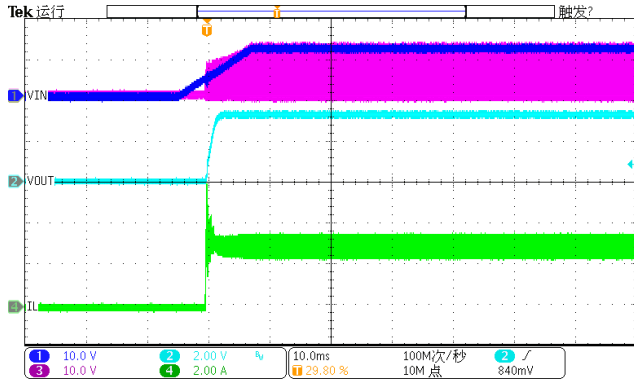

Figure 8. Power up

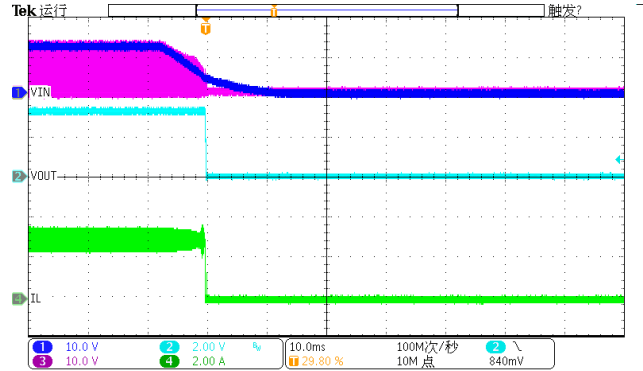

Figure 9. Power down

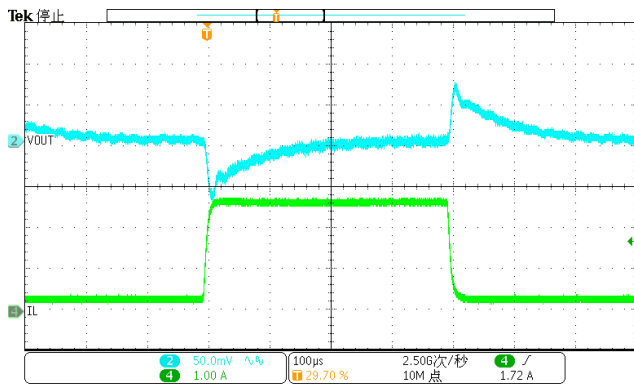

Figure 10. Load Transient (0.3A-2.7A, 1.6A/us)

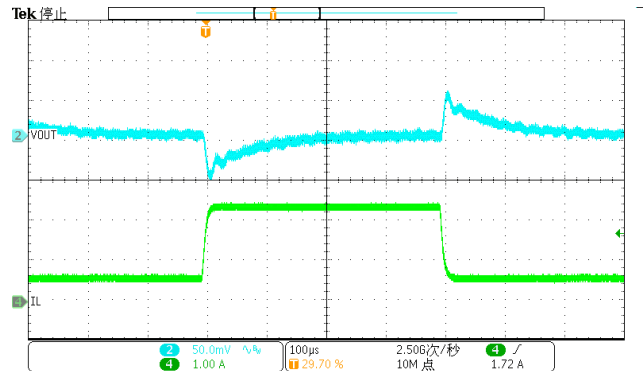

Figure 11. Load Transient (0.6A-2.4A, 1.6A/us)

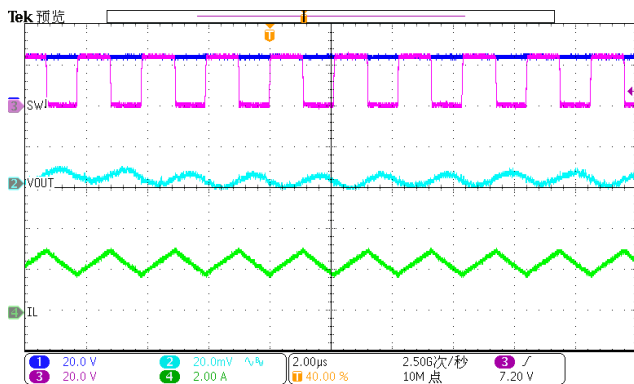

Figure 12. SW and Vout Ripple

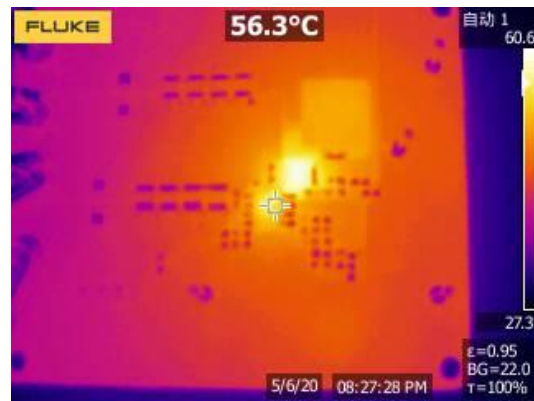

Figure 13. Thermal, 12VIN, 3.3Vout,3A

IMPORTANT NOTICE

This evaluation board kit being sold or provided by Silicon Content Technology is intended for use for ENGINEERING DEVELOPMENT OR EVALUATION PURPOSES ONLY and is not provided by SCT for commercial use. As such, the evaluation board herein may not be complete in terms of required design, marketing, and/or manufacturing related protective considerations, including but not limited to product safety measures typically found in finished commercial goods. The user assumes all responsibility and liability for proper and safe handling of the goods. Further, the user releases SCT from all claims arising from the handling or use of the goods. Due to the open construction of the product, it is the user's responsibility to take all appropriate precautions regarding electrostatic discharge. Also, be aware that the products herein may not be regulatory compliant or agency certified (FCC, UL, CE, etc.). No License is granted under any patent right or other intellectual property whatsoever. SCT assumes no liability for applications assistance, customer product design, software performance, or infringement of patents or any other intellectual property rights of any kind. Please read the Evaluation Board user's guide prior to handling the product. Persons handling this product must have electronics training and observe good laboratory practice standards. Common sense is encouraged. This notice contains important safety information about temperatures and voltages. For further safety concerns, please contact a SCT application engineer.