

SCT2280 Evaluation Board User's Guide

FEATURES

- Wide 4.5V-18V Input Voltage Range
- 0.6V-7V Output Voltage Range
- 8A Continuous Output Current
- Integrated 25mΩ/12mΩ R_{ds(on)} of HS/LS Power MOSFETs
- Fixed 1ms Soft-start Time
- Selectable 400KHz, 800KHz and 1.2MHz Switching Frequencies
- Selectable PWM, PFM and USM Operation Modes
- Cycle-by-Cycle Current Limiting
- Output Over-Voltage Protection
- Over-Temperature Protection
- Available in a QFN 12-leads 2mmx3mm Package

APPLICATIONS

- High End DTV
- Set-top Box, XDSL Modem, Personal Video Recorders
- Server, Cloud-Computing, Storage
- Telecom & Networking, Small-cell Base Stations, Point-of-Load (POL)
- IPCs, Factory Automation, PLC, Test Measurement

DESCRIPTION

The SCT2280 is a high efficiency synchronous step-down DC-DC converter with 4.5V-18V input voltage range and adjustable output voltage down to 0.6V. It offers a small saving 2mmx3mm QFN package that supplies continuous 8A output current. The device fully integrates high-side and low-side power MOSFETs with 25mΩ/12mΩ on-resistance to minimize the conduction loss.

The SCT2280 adopts a Constant On-Time (COT) control to provide fast transient response and easy loop stabilization. The switching clock frequency can be selected from 400KHz, 800KHz and 1.2MHz for optimization of the filter size and output voltage ripple.

The SCT2280 has the MODE pin to select Pulse Frequency Modulation (PFM) operation mode to achieve the light load power save, or Ultrasonic Mode (USM) to keep the switching frequency above audible frequency areas during light-load or no-load conditions.

The converter requires a minimum number of external components and is available in a QFN- 12 (2mmx3mm) package.

Board Number	IC Number
EV2280-B-04A	SCT2280

PERFORMANCE SUMMARY

Table 1. Performance

Specifications are at TA = 25°C

Parameter	Condition	Value
Input Voltage	DC up to V	4.5V-18V
Output Voltage		1V ± 1%
Output Current	Continuous DC current	8A
Frequency	Default	800KHz

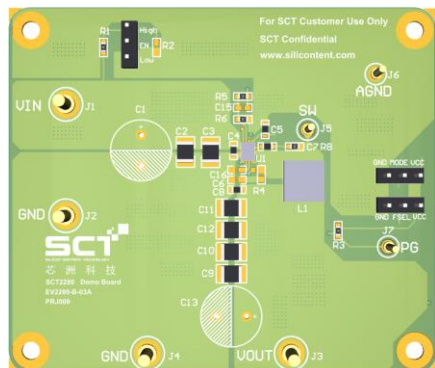

EV2280-B-04A Evaluation Board Top View

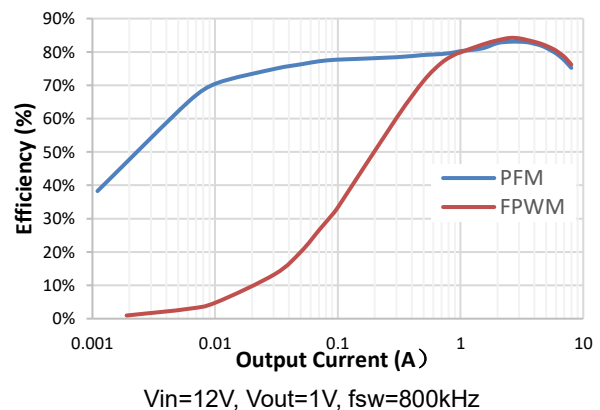

QUICK START PROCEDURE

Evaluation board EV2280-B-04A is easy to set up to evaluate the performance of the SCT2280. Refer to Figure 1 for proper measurement equipment setup and follow the procedure below:

- Place jumpers in the following positions:
 - J1, J2: Input terminal. Connect the power supply to the input of converter.
 - J3, J4: Output terminal. Connect the load to the output of converter.
 - JP1: Enable Jumper. Install ON shunt to connect EN pin to V_{in} through a 100K Ω resistor to enable IC. Install OFF shunt to disable IC.
 - JP2: Frequency select jumper. Install shunt to connect FSEL with VCC to set frequency at 1.2MHz, float jumper to set frequency at 800KHz, install shunt to connect FSEL with GND to set frequency at 400KHz.
 - JP3: Mode select jumper. Install shunt to connect MODE with VCC to set mode as FCCM, float jumper to set mode as USM, install shunt to connect MODE with GND to set mode as PFM.
- With power off, connect the input power supply to J1 and J2 terminals. Make sure that the input voltage does not exceed 18V, and supports sufficient current limit. Turn on the power at the input.
- Check the output voltage at J3 and J4 terminals. The output voltage should be 1V typical. Once the proper output voltage is established, adjust the load within the operating range and observe the output voltage regulation, output voltage ripple, efficiency and other parameters.
- To use the enable function, apply a digital input to the EN pin of JP1.
Users can place C1 if input wire is long and C13 for better load transient performance

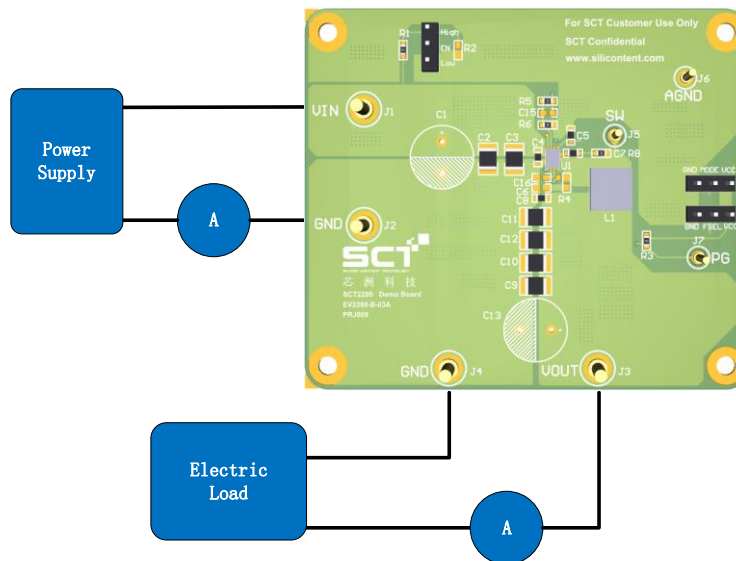

Figure 1. Proper Supply, Load and Measurement Equipment Setup

NOTE: When measuring the voltage ripple, care must be taken to avoid a long ground lead on the oscilloscope probe. Measure the input or output voltage ripple by touching the probe tip directly across relevant capacitor of VIN or VOUT. See Figure 2 for proper scope probe technique.



Figure 2. Measuring Voltage Ripple Across Terminals or Directly Across Ceramic Capacitor

SCHEMATIC DIAGRAM

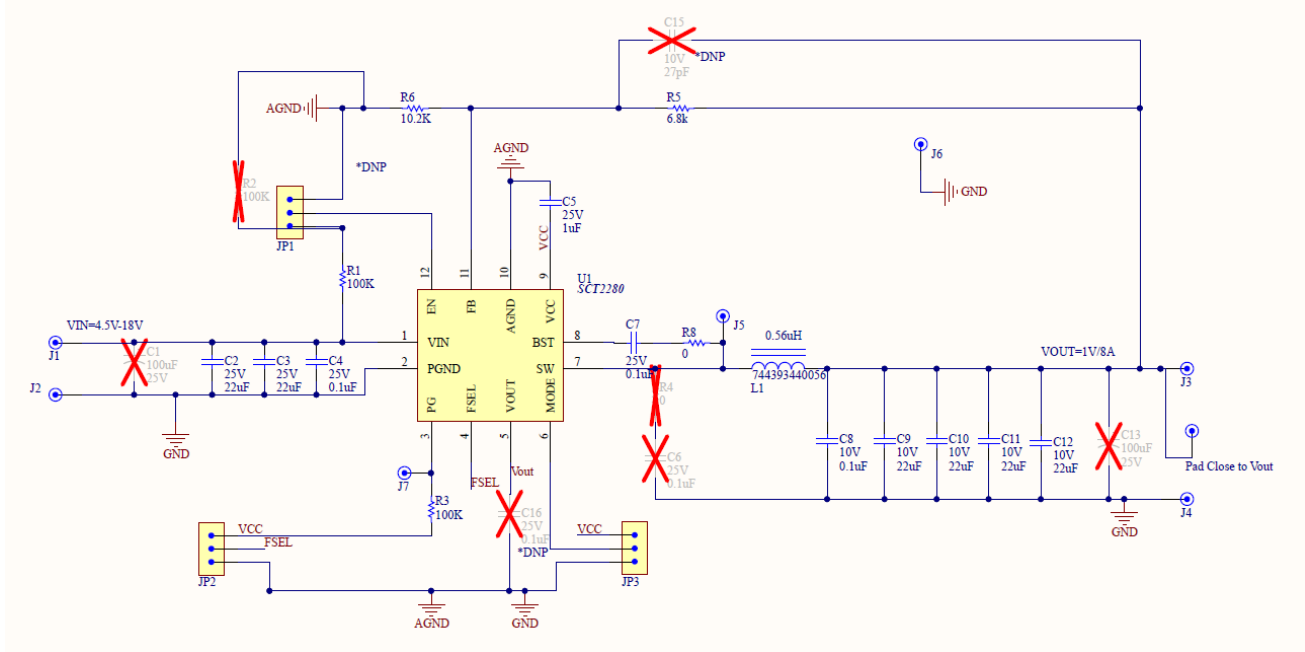

Figure 3. Evaluation Board Schematic

BILL OF MATERIALS

Table 2. Bills of Materials

Manufacture	Comment	Designator	Description	Quantity
PANASONIC	Not Install	C1 C13,	100uF, 35V, 10mm*12.5mm (DxL),F=5mm	0
Wurth Elektronik	885 012 109 014	C2, C3,	22uf, 25V, 1210	2
Wurth Elektronik	885 012 206 071	C4, C7	0.1uF, 25V, 0603	2
Wurth Elektronik	885 012 206 020	C8	0.1uF, 10V, 0603	1
Wurth Elektronik	885 012 106 022	C5	1uF, 25V, 0603	1
Wurth Elektronik	Not Install	C6	0.1uF, 10V, 0603	0
Wurth Elektronik	885 012 109 010	C9, C10, C11, C12	22uf, 16V, 1210	4
YAGEO	Not Install	C15	27pF,50V,0603	0
Wurth Elektronik	Not Install	C16	0.1uF, 10V, 0603	0
	Terminal 2.1	J1, J2, J3, J4	terminal	4
	Terminal 1.1	J5, J6, J7	terminal	3
Wurth Elektronik	613 003 111 21	JP1, JP2, JP3	Header, 100mil, 3x1, Tin plated, TH	3
Wurth Elektronik	744 393 440 056	L1	Inductor, Shielded, 0.56uH, 16A, 3.19mohms, SMT	1
YAGEO	RC0603TR-071100K	R1, R3	100K 1% 0603	2
YAGEO	Not Install	R2	100K 1% 0603	0
YAGEO	Not Install	R4	10ohm 1% 0603	0
YAGEO	RC0603FR-076K8L	R5	6.8k 1% 0603	1
YAGEO	RC0603FR-0710K2L	R6	10.2k 1% 0603	1
YAGEO	RC0603FR-070RL	R8	0 1% 0603	1
SCT	SCT2280	U1	SCT2280	1

PRINTED CIRCUIT BOARD LAYOUT

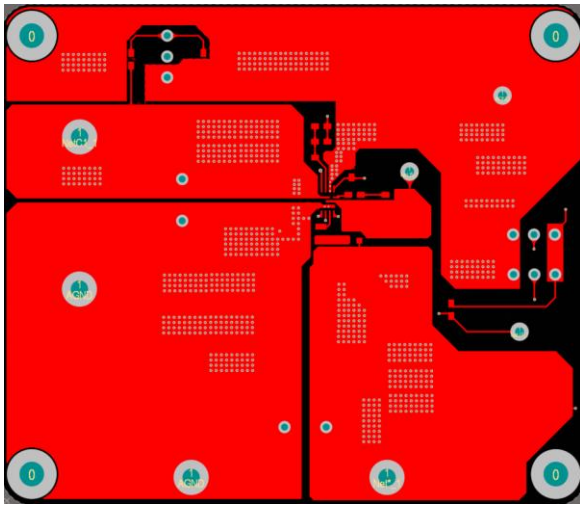

Figure 4. Top Layer

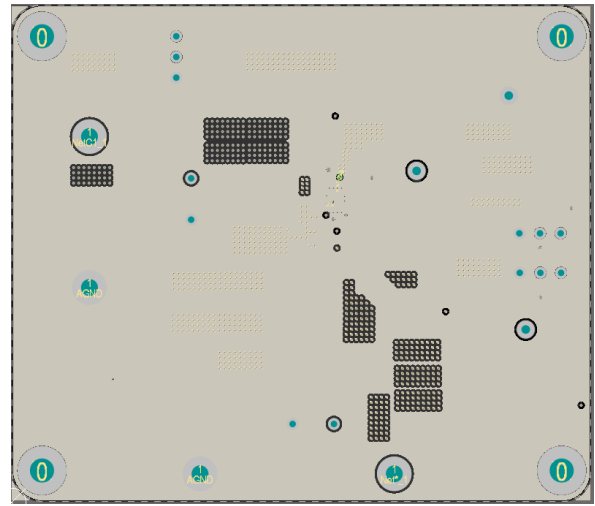

Figure 5. Inner Layer1

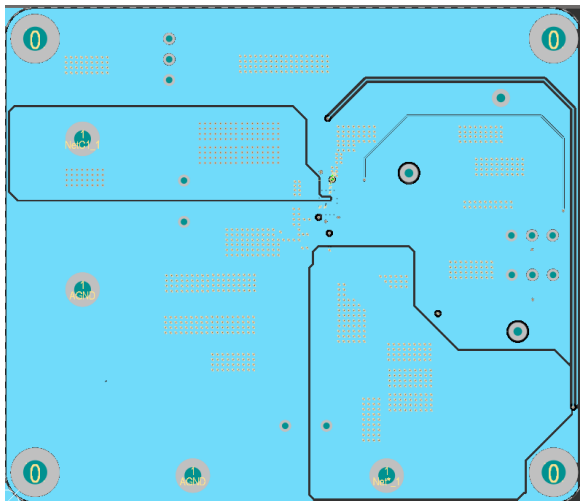

Figure 6. Inner Layer2

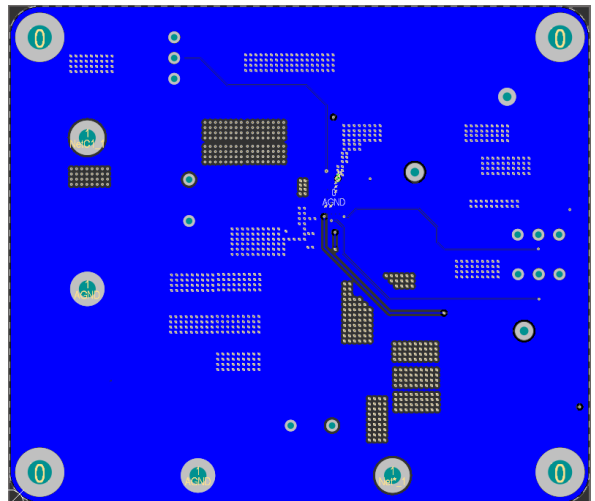

Figure 7. Bottom Layer

EVB TEST RESULTS

Vin=12V, Vout=1V, 8A loading, unless otherwise noted

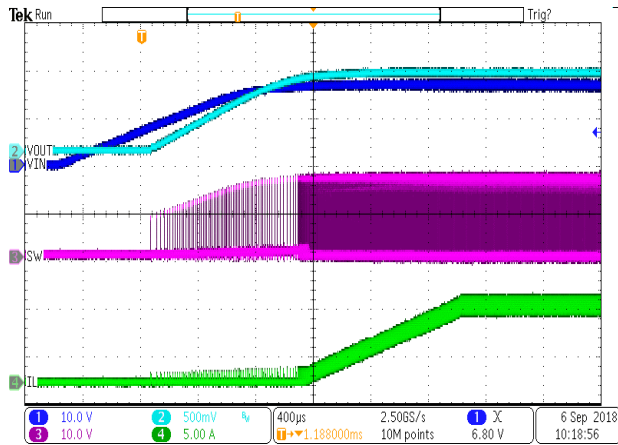

Figure 8. Power Up

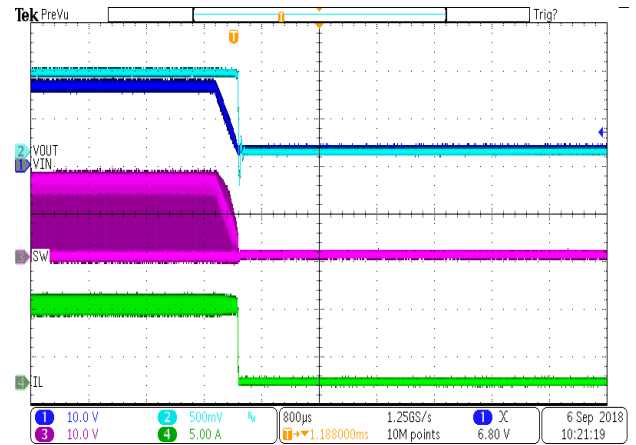

Figure 9. Power Down

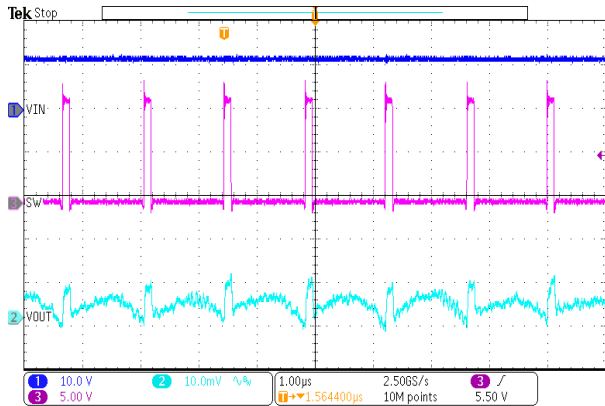

Figure 10. Steady State Ripple
Iout=2A

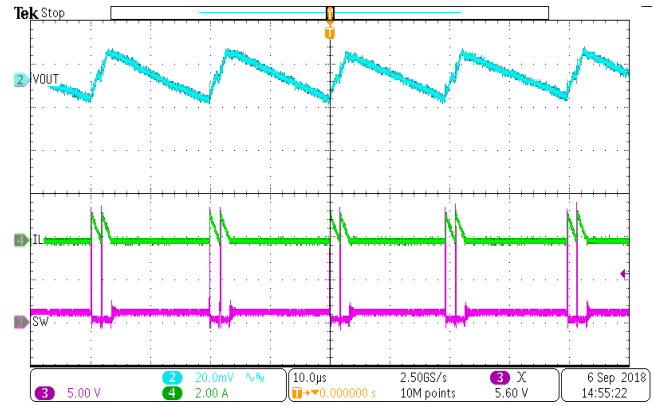

Figure 11. Steady State Ripple
Iout=600mA

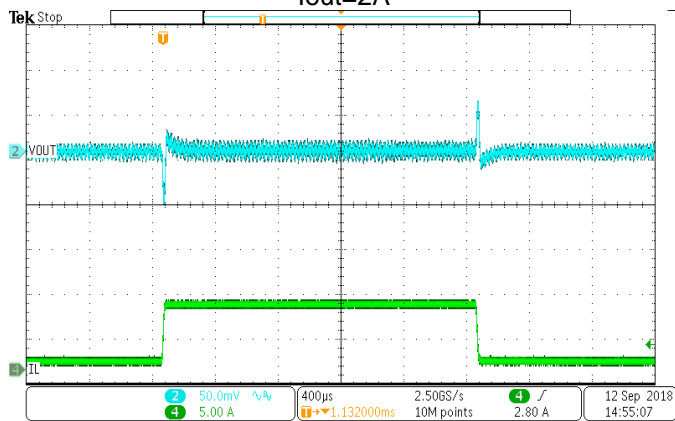

Figure 12. Load Transient
(0.2A-7.8A, SR=250mA/us)

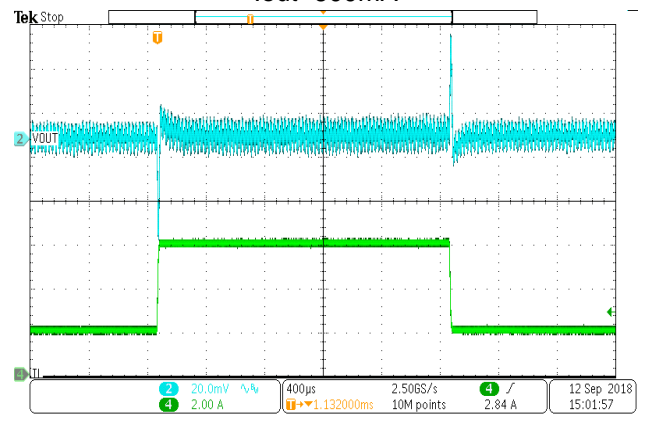

Figure 13. Load Transient
(0.2A-0.4A, SR=250mA/us)

IMPORTANT NOTICE

This evaluation board kit being sold or provided by Silicon Content Technology is intended for use for ENGINEERING DEVELOPMENT OR EVALUATION PURPOSES ONLY and is not provided by SCT for commercial use. As such, the evaluation board herein may not be complete in terms of required design, marketing, and/or manufacturing related protective considerations, including but not limited to product safety measures typically found in finished commercial goods. The user assumes all responsibility and liability for proper and safe handling of the goods. Further, the user releases SCT from all claims arising from the handling or use of the goods. Due to the open construction of the product, it is the user's responsibility to take all appropriate precautions regarding electrostatic discharge. Also, be aware that the products herein may not be regulatory compliant or agency certified (FCC, UL, CE, etc.). No License is granted under any patent right or other intellectual property whatsoever. SCT assumes no liability for applications assistance, customer product design, software performance, or infringement of patents or any other intellectual property rights of any kind. Please read the Evaluation Board user's guide prior to handling the product. Persons handling this product must have electronics training and observe good laboratory practice standards. Common sense is encouraged. This notice contains important safety information about temperatures and voltages. For further safety concerns, please contact a SCT application engineer.