

## 12.6V, 7A Fully Integrated High Efficiency Synchronous Boost Converter

### FEATURES

- Wide Input Voltage Range: 2.7V-12V
- Wide Output Voltage Range: 4.5V-12.6V
- Fully Integrated 17mΩ High Side FET and 16mΩ Low Side FET
- Programmable and Up to 9.5A Peak Switch Current Limit
- Adjustable Switching Frequency: 200KHz to 2.2MHz
- PFM Operation Mode at Light Load (SCT1270)
- Forced PWM Operation Mode at Light Load (SCT12701)
- Internal Soft Start and External Compensation
- Cycle-by-Cycle Overcurrent Protection
- Output Overvoltage Protection
- Thermal Shutdown Protection: 160°C □
- QFN-11 2mm x 2.5mm Package

### APPLICATIONS

- Bluetooth Speaker
- Portable POS Terminal
- E-Cigarette
- Lighting

### DESCRIPTION

The EV1270-B-02A Evaluation Board is designed to demonstrate the capabilities of SCT1270, a high efficiency fully integrated synchronous boost converter. It offers a very compact solution to achieve up to small size power solution for portable equipment. The constant off-time peak current-mode operation provides fast transient response and eases loop stabilization. The device features include over-current protection, output over voltage protection and thermal shutdown. The SCT1270 is available in a space-saving 11-pin QFN 2mmx2.5mm package.

This user's guide describes the characteristics, operation and the use of the EV1270-B-02A Evaluation Module including EVM specifications, recommended test setup, test result, schematic diagram, bill of materials, and the board layout.

Board Number	IC Number
EV1270-B-02A	SCT1270

### PERFORMANCE SUMMARY

Specifications are at TA = 25°C

Table 1. Performance

Parameter	Condition	Value
Input Voltage	DC up to 12V	2.7V-12.6V
Output Current	Continuous DC current	1A
Frequency	Default	500KHz

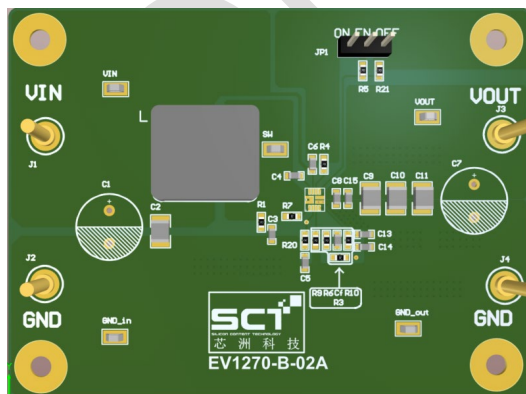

EV1270-B-02A Evaluation Board Top View

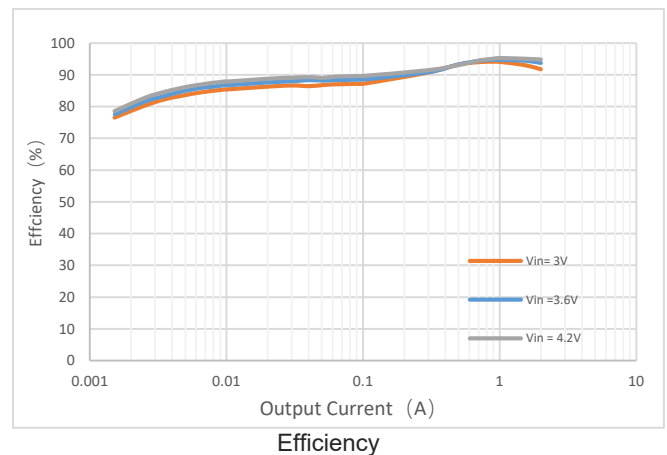

## QUICK START PROCEDURE

Evaluation board EV1270-B-02A is easy to set up to evaluate the performance of the SCT1270. Refer to Figure 1 for proper measurement equipment setup and follow the procedure below:

1. Place jumpers in the following positions:
  - JP1: ON Connect EN pin to  $V_{CC}$  to enable IC.
2. With power off, connect the input power supply to J1  $V_{IN}$  connector and J2 GND connector. Turn on the power at the input. Make sure that the input voltage does not exceed 12V, and supports sufficient current limit.
3. Check the output voltage at J3. The output voltage should be 9V typical. Once the proper output voltage is established, adjust the load within the operating range and observe the output voltage regulation, output voltage ripple, efficiency and other parameters.
4. To use the enable function, apply a digital input to the EN pin of JP1.

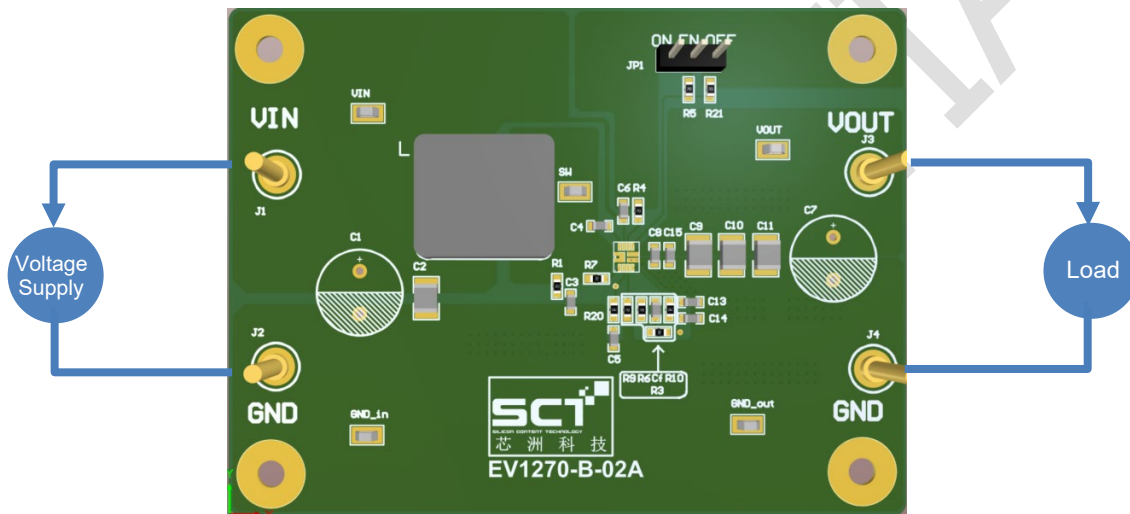

Figure 1. Proper Supply, Load and Measurement Equipment Setup

### NOTE.

When measuring the voltage ripple, care must be taken to avoid a long ground lead on the oscilloscope probe. Measure the input or output voltage ripple by touching the probe tip directly across relevant capacitor of  $V_{IN}$  or  $V_{OUT}$ . See Figure 2 for proper scope probe technique.



Figure 2. Measuring Voltage Ripple Across Terminals or Directly Across Ceramic Capacitor

## SCHEMATIC DIAGRAM

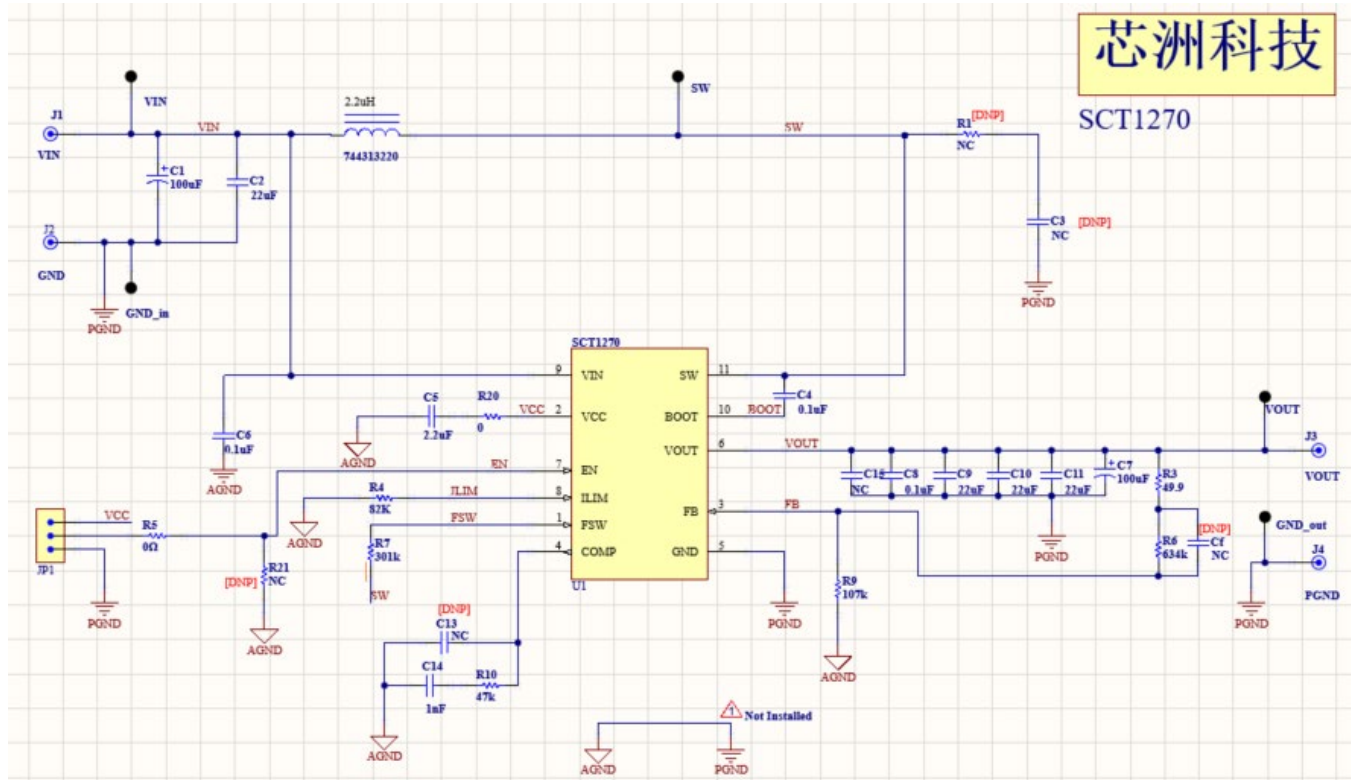

Figure 3. Evaluation Board Schematic

## BILL OF MATERIALS

Table 2. Bills of Materials

Manufacture	Comment	Designator	Description	Quantity
Würth Elektronik	744313220	L	2.2uH, Isat=18A,DCR=5.7mΩ	1
Würth Elektronik	Cap_Pol	C1, C7	Poly_Cap, 100uF,35V, +/- 20%	2
Würth Elektronik	885 012 106 022	C2, C9, C10, C11	CAP, CERM, 22uF, 25V, +/- 10%, X7R, 1210	4
Würth Elektronik	Not Install	C3, C13, C15, Cf	CAP, CERM, NC, 25V, +/- 10%, X7R, 0603	4
Würth Elektronik	885 012 206 071	C4, C6, C8	CAP, CERM, 0.1uF, 25V, +/- 10%, X7R, 0603	3
Würth Elektronik	885012106018	C5	CAP, CERM, 2.2uF, 16V, +/- 10%, X7R, 0603	1
Würth Elektronik	885012206063	C14	CAP, CERM, 1nF, 25V, +/- 10%, X7R, 0603	1
Würth Elektronik	Testpoint	GND1, GND2, SW1, VIN1, VOUT1	Test Point	5
	Terminal_single	J1, J2, J3, J4	terminal	4
BOOMEL	Jumper3	JP1	Through Hole 2.54mm 1*3P	1
YAGEO	Not Install	R1, R2, R21	Resistor, NC, 1%, 0.1W, 0603	3
YAGEO	RC0603FR-0749R9L	R3	Resistor, 49.9Ω, 1%, 0.1W, 0603	1
YAGEO	RC0603FR-07191KL	R4	Resistor, 88kΩ, 1%, 0.1W, 0603	1
YAGEO	RC0603FR-070RL	R5, R20	Resistor, 0Ω, 1%, 0.1W, 0603	2
YAGEO	AC0603FR-07634KL	R6	Resistor, 576kΩ, 1%, 0.1W, 0603	1
YAGEO	RC0603FR-07301KL	R7	Resistor, 308kΩ, 1%, 0.1W, 0603	1
YAGEO	AC0603DR-07107KL	R9	Resistor, 107kΩ, 1%, 0.1W, 0603	1
YAGEO	RC0603FR-0717K4L	R10	Resistor, 47kΩ, 1%, 0.1W, 0603	1
Silicon Content Technology	U1	SCT1270	VIN=4.5V-12.6V	1

**PRINTED CIRCUIT BOARD LAYOUT**

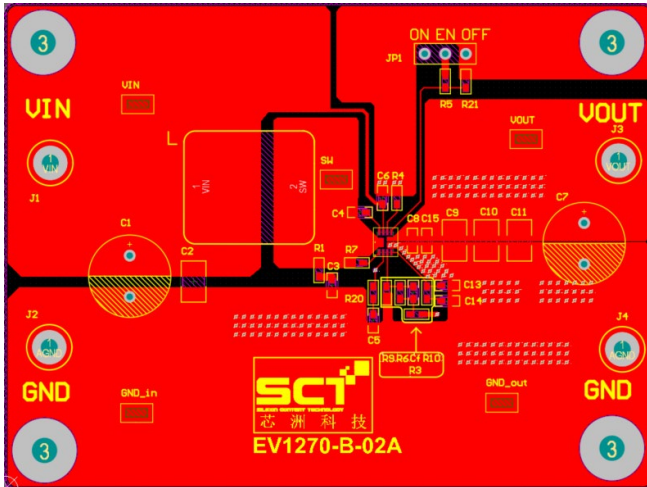

Figure 4. Top Layer

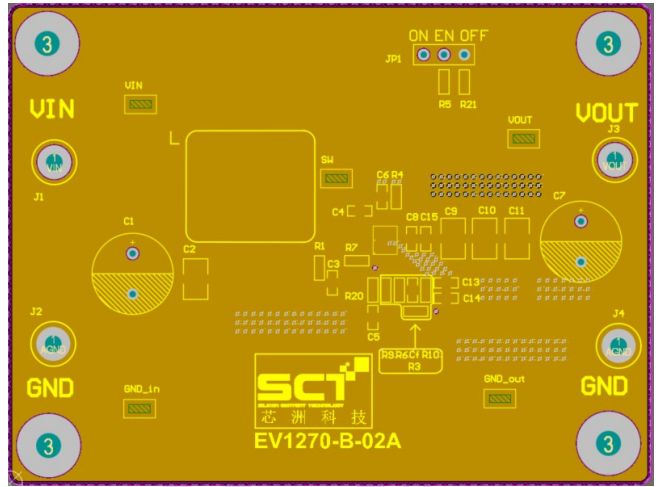

Figure 5. Internal Layer 1

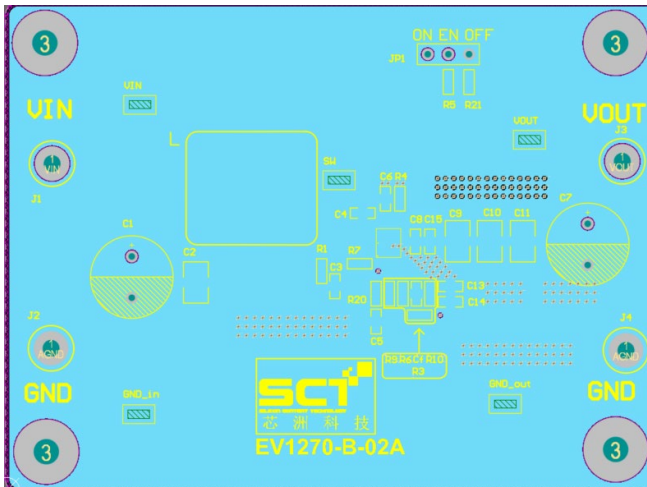

Figure 6. Internal Layer 2

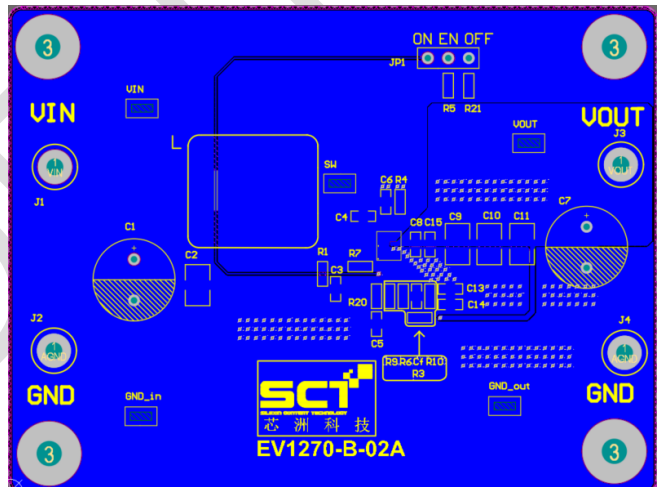

Figure 7. Bottom View

## EVB TEST RESULTS

Vin=3.6V, Vout=9V unless otherwise noted

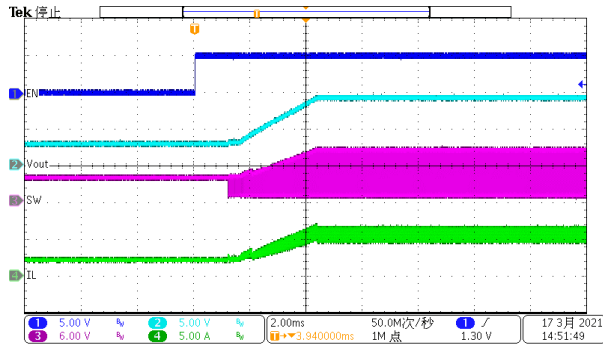

Figure 8. Power up

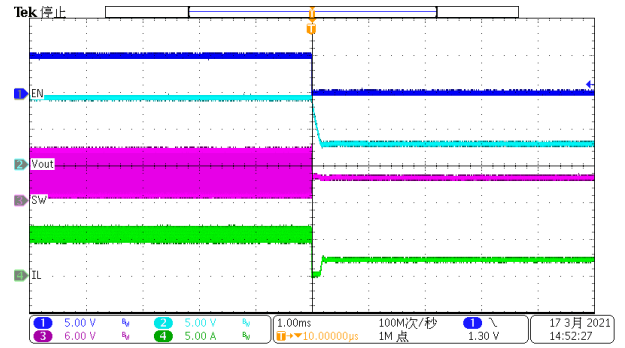

Figure 9. Power down

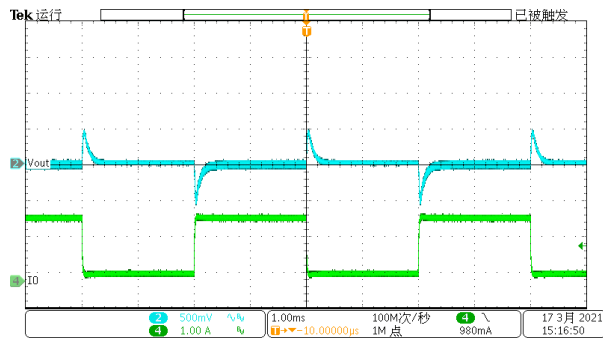

Figure 10. Load Transient (0.2A-1.8A, 1.6A/us)

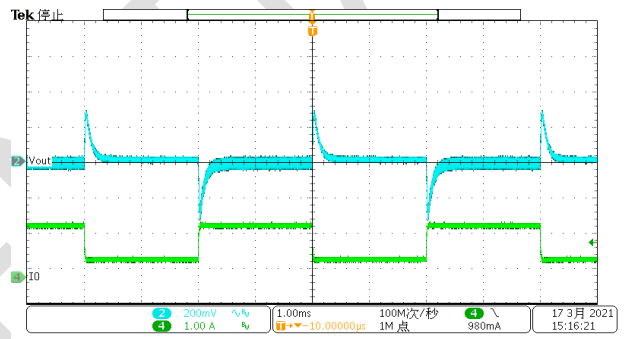

Figure 11. Load Transient (0.5A-1.25A, 1.6A/us)

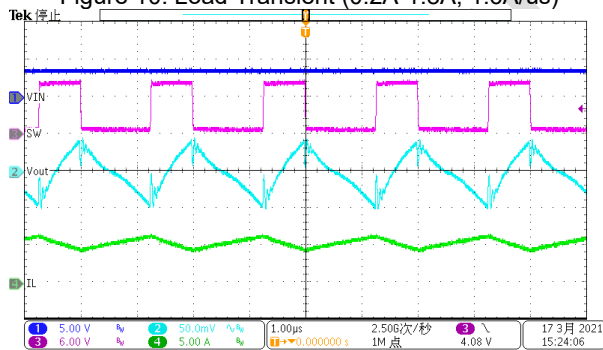

Figure 12. Output Ripple (Iload=2A)

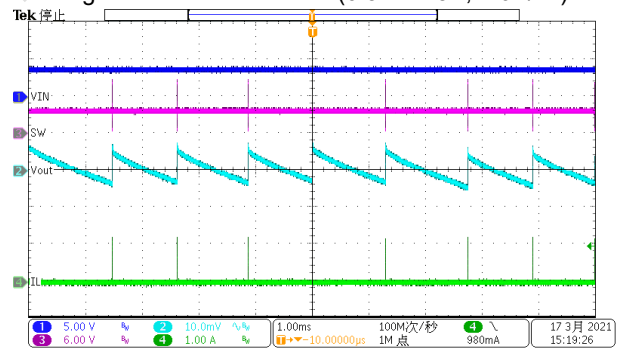

Figure 13. Output Ripple (Iload=0A)

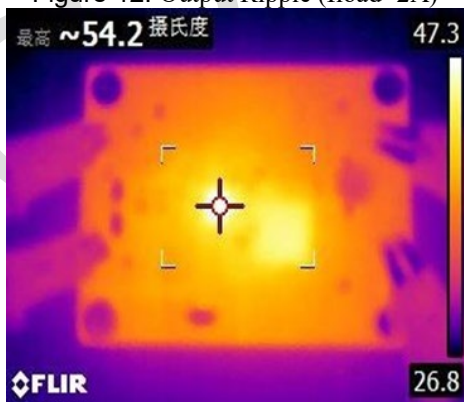

Figure 14. Thermal (Iload=2A)

## OPTIONAL MODIFICATION

### Switching Frequency

The resistor connected from FSW to SW R7 (Default 301KΩ) sets switching frequency of the converter. Use equation 1 to set a desired frequency.

$$R_{FREQ} = \frac{6 * (\frac{1}{f_{SW}} - T_{DELAY}) * \frac{V_{OUT}}{V_{IN}}}{C_{FREQ}} \quad (1)$$

where:

- $f_{SW}$  is the desired switching frequency
- $T_{DELAY} = 70 \text{ ns}$
- $C_{FREQ} = 35 \text{ pF}$
- $V_{IN}$  is the input voltage
- $V_{OUT}$  is the output voltage

**Table 3. R<sub>FSW</sub> Value for Common Switching Frequencies (Vin=3.6V, Vout=9V, Room Temperature)**

Fsw	R <sub>FSW</sub>
200 KHz	830 KΩ
350 KHz	460 KΩ
520 KHz	300 KΩ
850 KHz	162 KΩ
1000 KHz	140 KΩ
2000 KHz	55 KΩ

### Peak Current Limit

The resistor R4 at ILIM pin sets default peak input current limit at 7A typical. Use equation 2 to set inductor peak current limit

$$I_{LIM} = \frac{800}{R_{LIM}} \quad (2)$$

where:

- $I_{LIM}$  is the peak current limit
- $R_{LIM}$  is the resistance of ILIM pin to ground

**Table 4. R<sub>LIM</sub> Value for Inductor Peak Current (Vin=3.6V, Vout=9V, L=2.2uH, Room Temperature)**

I <sub>LIM</sub>	R <sub>LIM</sub>
9.5 A	84 KΩ
8 A	100 KΩ
5.6A	142 KΩ
4A	200 KΩ

### Output Voltage

The output voltage is set by an external resistor divider R6 and R9 in typical application schematic. The value of R6 can be calculated by equation 3. A minimum current of typical 20uA flowing through feedback resistor divider gives good accuracy and noise covering.

$$R_6 = \frac{(V_{OUT} - V_{REF}) \times R_9}{V_{REF}} \quad (3)$$

where:

- $V_{REF}$  is the feedback reference voltage, typical 1.0V

**Table 5. Feedback Resistor R<sub>3</sub> R<sub>4</sub> Value for Output Voltage (Room Temperature)**

V <sub>OUT</sub>	R <sub>6</sub>	R <sub>9</sub>
5 V	360 KΩ	90 KΩ
9 V	720 KΩ	90 KΩ
12 V	990 KΩ	90 KΩ

## IMPORTANT NOTICE

This evaluation board kit being sold or provided by Silicon Content Technology is intended for use for ENGINEERING DEVELOPMENT OR EVALUATION PURPOSES ONLY and is not provided by SCT for commercial use. As such, the evaluation board herein may not be complete in terms of required design, marketing, and/or manufacturing related protective considerations, including but not limited to product safety measures typically found in finished commercial goods. The user assumes all responsibility and liability for proper and safe handling of the goods. Further, the user releases SCT from all claims arising from the handling or use of the goods. Due to the open construction of the product, it is the user's responsibility to take all appropriate precautions regarding electrostatic discharge. Also, be aware that the products herein may not be regulatory compliant or agency certified (FCC, UL, CE, etc.). No License is granted under any patent right or other intellectual property whatsoever. SCT assumes no liability for applications assistance, customer product design, software performance, or infringement of patents or any other intellectual property rights of any kind. Please read the Evaluation Board user's guide prior to handling the product. Persons handling this product must have electronics training and observe good laboratory practice standards. Common sense is encouraged. This notice contains important safety information about temperatures and voltages. For further safety concerns, please contact a SCT application engineer.

CONFIDENTIAL